

SOCKET/FEMALE CONTACT CAVITY IDENTIFICATION ON REAR

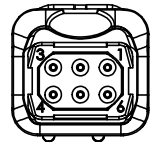
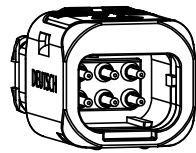

PIN/MALE CONTACT CAVITY IDENTIFICATION ON REAR

2:1

NOTES:

1. MARKED WITH DEUTSCH PART No., DEUTSCH (HASTINGS) CAGE CODE AND DATE CODE.

PART NUMBER EXAMPLE: D369 - P 6 6 - N P 1

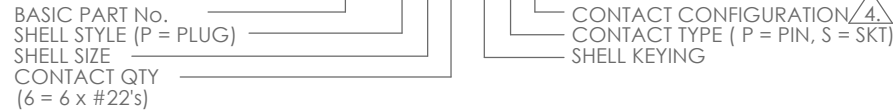

2. PERFORMANCE:  
TEMPERATURE RANGE : -55°C TO +175°C. INSULATION RESISTANCE : >5000 MΩ.  
DIELECTRIC WITHSTAND: 1000VRMS, <2mA. SEALING: 15KM(50000FT) ALTITUDE / IP67  
DURABILITY : 500 MATING CYCLES MIN. FLUID RESISTANCE: I.A.W. EN2591-315.  
FLAMMABILITY, SMOKE AND TOXICITY: I.A.W. FAR 25.853 APPENDIX F.

3. INSERTION/EXTRACTION TOOL (M81969/14-01 OR EQUIVALENT) SUPPLIED SEPARATELY.

4. Contact Configuration	Contact Description	Contact P/N (OR EQUIVALENT)		Crimp Positioner		Crimp Tool	Wire Accommodation	Current Rating
		Pin	Socket	Pin	Socket			
0		NO CONTACTS SUPPLIED						
1	CRIMP, COPPER WIRE	38941-22	38946-22	M22520/2-09	M22520/2-06	M22520/2-01	22-28 AWG	5A (22 AWG)
2	CRIMP, ALUMINIUM WIRE	200-1042-22	200-1142-22	KAL2		ALNP 22-A	22 AWG	5A
3	CRIMP, COPPER WIRE (ENLARGED WIRE)	182-0860-22	182-0862-22	M22520/2-09	M22520/2-06	M22520/2-01	20-24 AWG	5A (20 AWG)

5. MATERIALS:

COMPONENT	MATERIAL (FINISH: NONE IN ALL CASES)
SEALS	SILICONE / FLUOROSILICONE BLEND RUBBER PER AMS-R-25988 TYPE II, CLASS I, GRADE 40
BODY / INSERT COMPONENTS	POLYETHERIMIDE, 10% GLASS FILLED PER ASTM D 5205 or POLYETHERETHERKETONE, 450G, PER MIL-P-46183 TYPE I

6. MAXIMUM WEIGHT (WITHOUT CONTACTS):  
2.4g (PIN INSERT), 2.6 (SKT INSERT).

AB	DUK-65685	RBC	HD	RBC	GLB	11/06/2015
ISSUE	CHANGE NOTE	DRAWN	CHECKED	APP. ENG.	APP. MARKETING	DATE

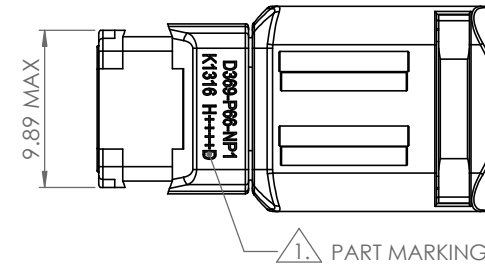
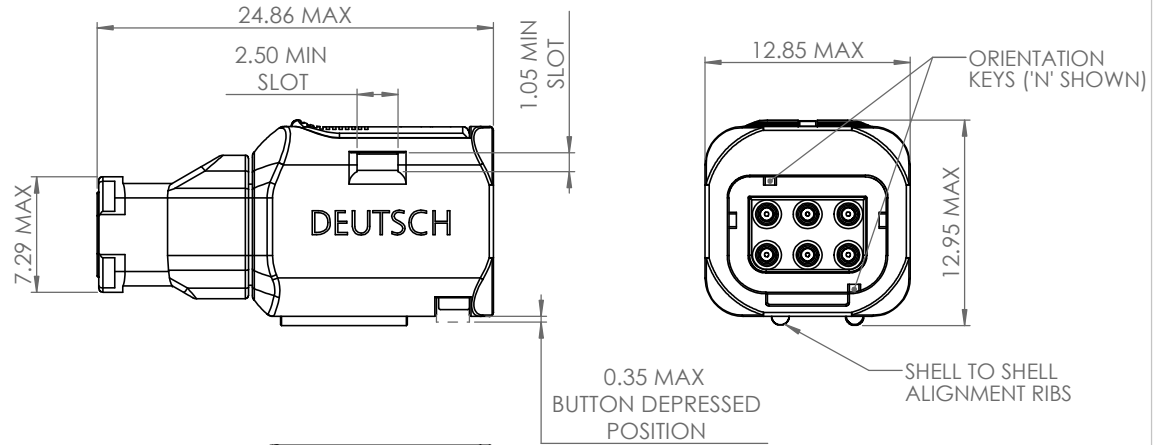

SHELL KEYING

ORIENTATION	COLOUR
N	BLACK
A	DARK RED
B	DARK BLUE
C	DARK GREEN
D	YELLOW

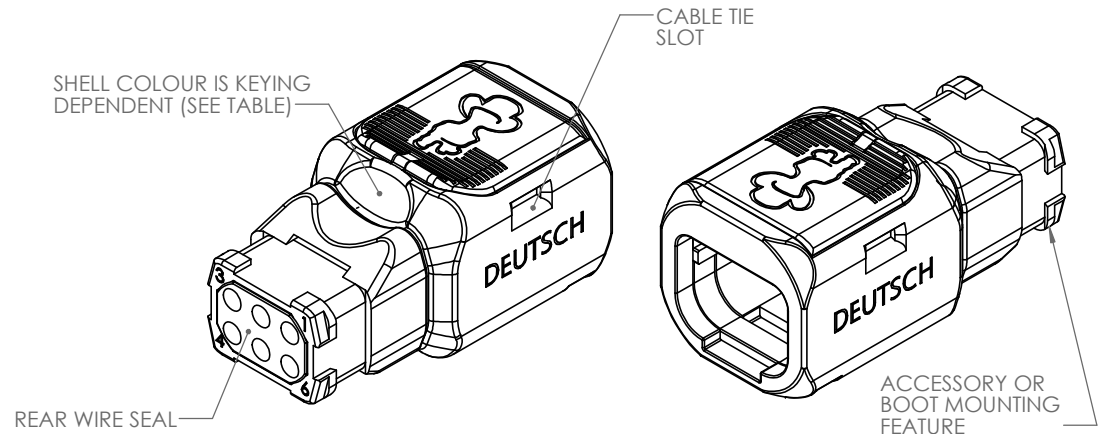

MATERIAL	SEE NOTES	THIS INFORMATION IS CONFIDENTIAL AND PROPRIETARY TO TYCO ELECTRONICS CORPORATION AND ITS WORLDWIDE SUBSIDIARIES AND AFFILIATES (TE). IT MAY NOT BE DISCLOSED TO ANYONE, OTHER THAN TE PERSONNEL, WITHOUT AUTHORIZATION FROM TE (www.TE.com).	 <b>DEUTSCH</b>		
HEAT TREATMENT & FINISH					
PACKAGING					
TITLE	D369 PLUG, SHELL SIZE 6, 6 WAY	TITLE	TYPE	CUSTOMER DRAWING	DRAWING NUMBER
SCALE	3:1				611252-6-ENV
DIMENSIONS IN MILLIMETRES UNLESS OTHERWISE STATED		ST LEONARDS ON SEA, EAST SUSSEX, TN38 9RF TEL. +44 (0)1424 852721			